

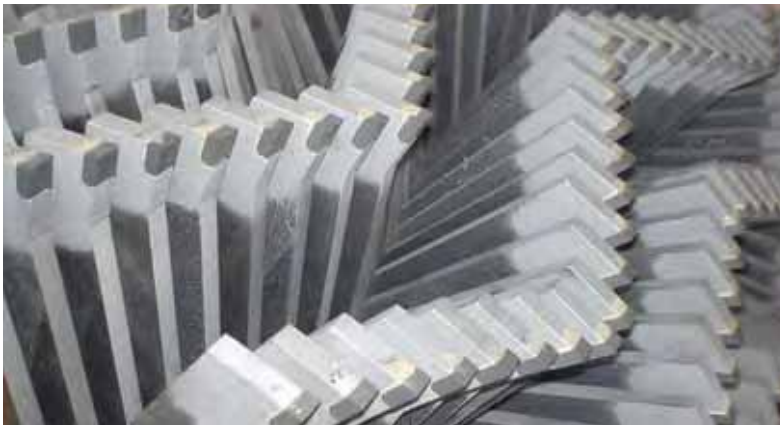

CelluloseMILL®
S A N I - G R O U P . C O M



Sanipro
Partners

CELLULOSEMILL



CelluloseMILL[®]
S A N I - G R O U P . C O M

Cellulose MILL[™] is your specialist for cellulose mills with hammers or discs (known as crushers). Treated or untreated celluloses can be processed by our mills due to the special carbide teeth.

Our mills are widely used in the disposable industry to produce the cellulose FLUFF for baby diapers, adult incontinence, feminine hygiene sanitary napkins, panty shields (liners), underpads, meat pads, Airlaid and cellulose Raw Material.

Our mills comes with Double cellulose feeding entrance of 10" or 20", controlled by brushless motor for high accuracy and splicing.

Customized mills are available. We also offer spare parts for wearing components.

OUR PRODUCTS:

Complete units:

- **DISC MILL** diameter 310 mm;
- **HAMMER / DISC MILL** diameter 508 mm;
- **SPECIAL EXECUTION;**
- **SPARE PARTS DIVISION;**
- **PROTOTYPES.**

Spare parts for mills wearing components:

- rotors;
- bearings;
- breaking bars;
- motors.

www.cellulosemill.com

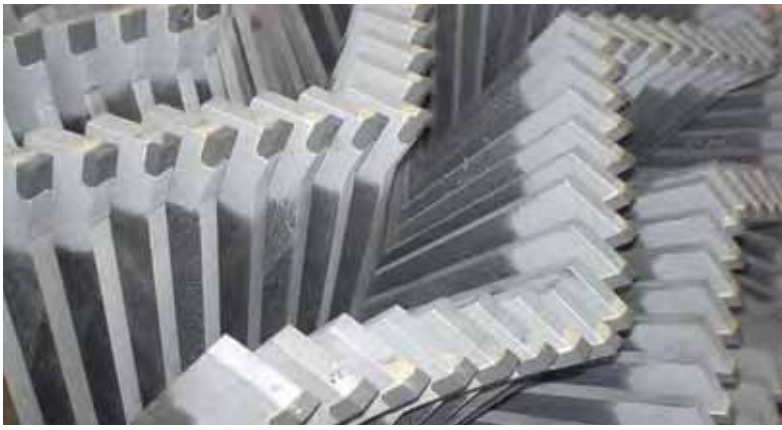

**Sanipro
Partners**

CELLULOSEMILL Screenless Disc Mill

SCREENLESS DISC MILL 20"+10"

CelluloseMILL[®]
SANI-GROUP.COM



Description

- 1 Cellulose pulp sheet infeed
- 2 Motor
- 3 Motor regulation with splicing
- 4 Transmission
- 5 Rotor with discs
- 6 Cellulose fluff outfeed

Characteristics

- Cellulose sheet infeed width: 20" or 10";
- Disc diameter: 310 mm;
- Disc thickness: 2 mm or upon request;
- Disc HSS or carbide teeth;
- Advised RPM: 4500 RPM;
- Defibration capacity with 1 sheet of cellulose: 700 kg/hour;
- Reel width 20" or 10" upon request;
- Long fibers output (Av. 3mm);
- No Knots;
- Low power consumption;
- Motor 37 or 55 Kw;
- **Automatic splicing;**
- High rpm;
- Delivery time 3 months;
- Warranty 12 months;
- Fit on any converter.

Options

Disc rotor carbide: all discs have a carbide head (2 mm width or more) complete of supports and bearings.

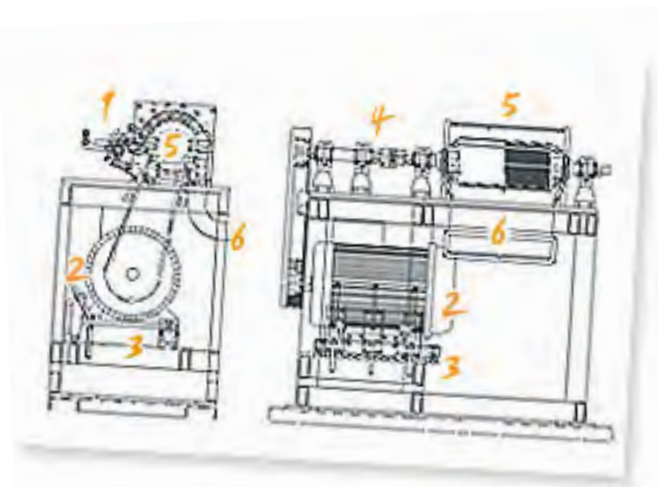

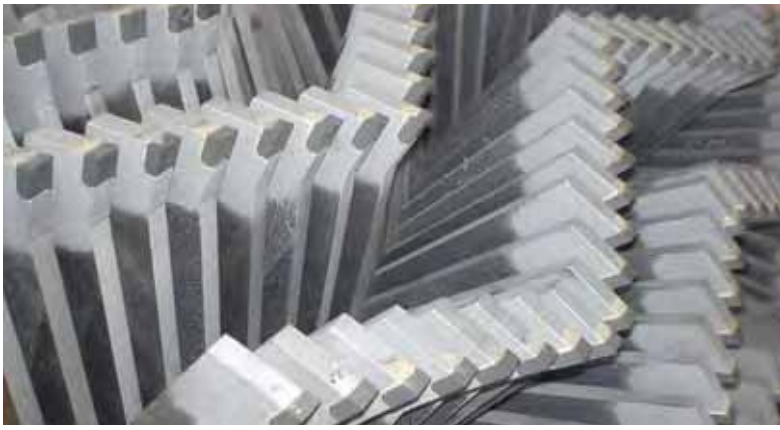

**Sanipro
Partners**

CELLULOSEMILL Hammer Mill

HAMMER MILL 10" *for all type of pulp in reels*

CelluloseMILL[®]
S A N I - G R O U P . C O M

Description

Hammer mill for the fiberization of any kind of treated or untreated cellulose pulp.

The mill has to be located close to the pad forming section and it is composed of:

- main support frame;
- anti-vibrating feet;
- all the part assembled are burnished or galvanized;
- the mill rotor is completed of 34 stars of 8 treated hammers, each 272 fixed hammers have a carbide head and they are positioned in "chevron" ("V") or "W" (upon request).

Characteristics

- Cellulose sheets infeed width: 10";
- Cellulose outfeed dimension: 300x220 mm;
- Hammer diameter: 508 mm;
- Hammer thickness: 8 mm;
- Hammer teeth in carbide;
- Advised RPM: 3000 RPM;
- Defibration capacity with 1 sheet of cellulose: 400 kg/hour;
- Defibration capacity with 2 sheets of cellulose: 650 kg/hour.

Options

Disc rotor carbide: all discs have a carbide head (2 mm width or more) complete of supports and bearings.

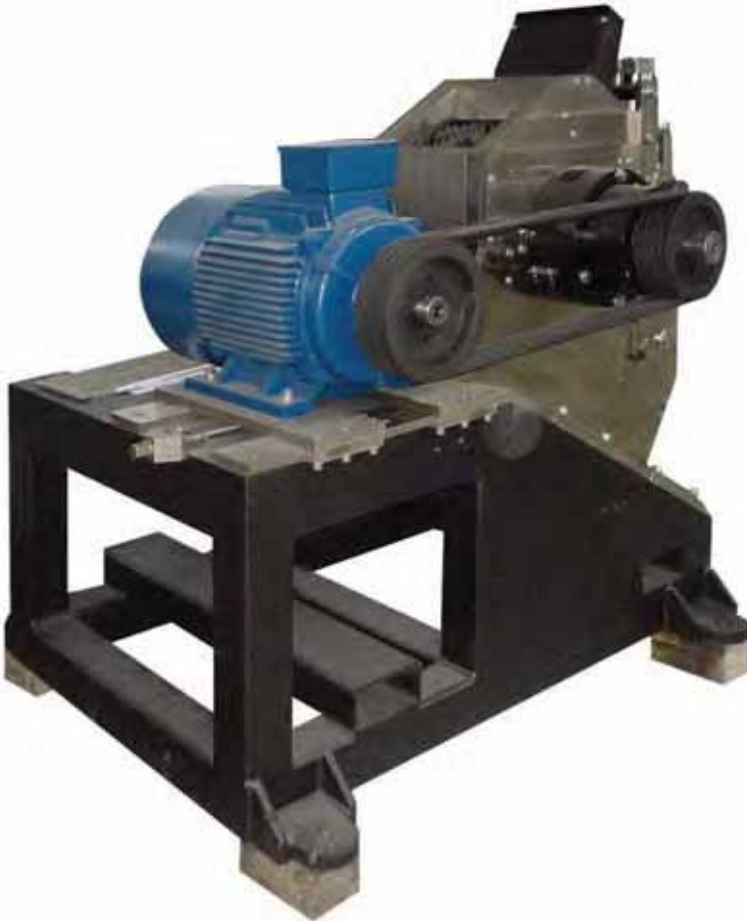

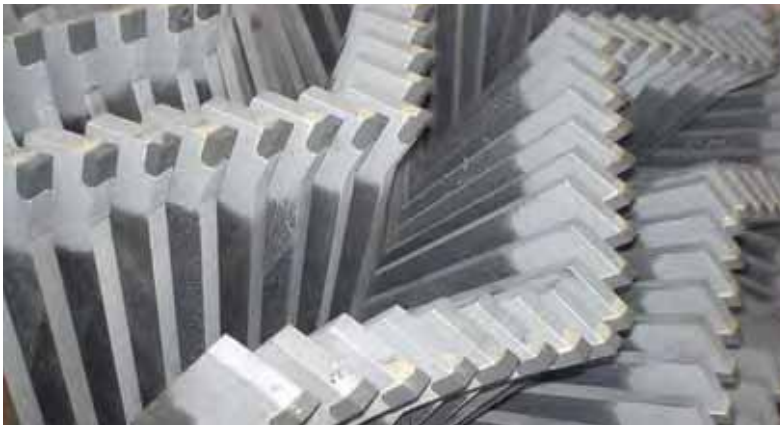

**Sanipro
Partners**

CELLULOSEMILL Hammer Mill

HAMMER MILL 20" *for all type of pulp in reels*



Option Disc Rotor for Hammer Mill

CelluloseMILL[®]
SANI-GROUP.COM

Hammer mill for the fiberization of any kind of treated or untreated cellulose pulp. The mill has to be located close to the pad forming section and it is composed of:

- main support frame;
- anti-vibrating feet;
- cellulose sheet infeed stand mounted on an articulated support for easy access and maintenance;
- all the parts assembled are burnished or galvanized;
- the mill rotor is completed of 68 stars of 8 treated hammers, each 544 fixed hammers have a carbide head and they are positioned in "chevron" ("V") or "W" (upon request).

Characteristics

- Cellulose sheets infeed width: 20";
- Hammer diameter: 508 mm;
- Hammer thickness: 8 mm;
- Hammer teeth in carbide;
- Advised RPM: 3000 RPM;
- Defibration capacity with 1 sheet of cellulose: 740 kg/hour;
- Defibration capacity with 2 sheets of cellulose: 1.200 kg/hour.

Options

Disc rotor carbide: all discs have a carbide head (2 mm width or more) complete of supports and bearings.

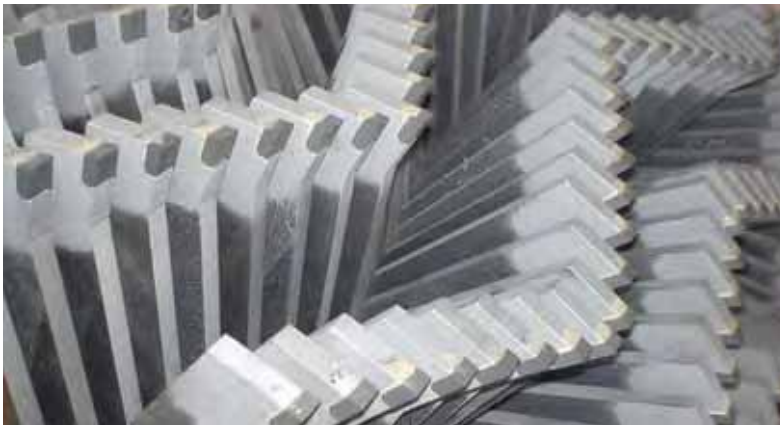

Sanipro
Partners

CELLULOSEMILL Hammer Mill

HAMMER MILL

CelluloseMILL[®]
SANI - GROUP . COM

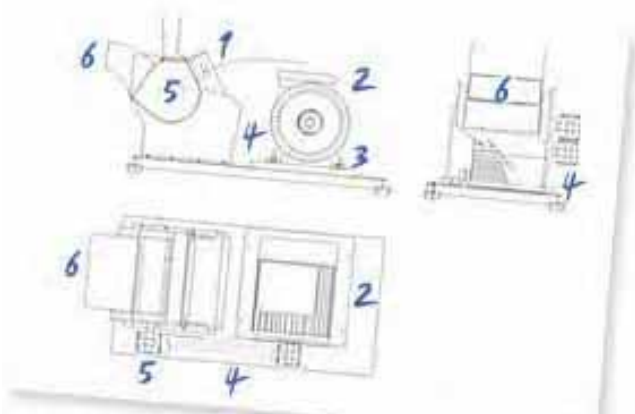

Characteristics

- Fiberization of any kind of treated or untreated cellulose pulp (1 or 2 sheet infeed);
- Reel width 20" = 508 mm;
- Heat detector alarm included;
- Automatic splicing;
- Tungsten teeth;
- Easy maintenance;
- Delivery time 3 months;
- Warranty 12 months;
- Fit on any converter.

Description

- 1 Cellulose pulp sheet infeed
- 2 Motor
- 3 Motor regulation
- 4 Transmission
- 5 Rotor with fixed hammers mounted in chevron
- 6 Cellulose fluff outfeed



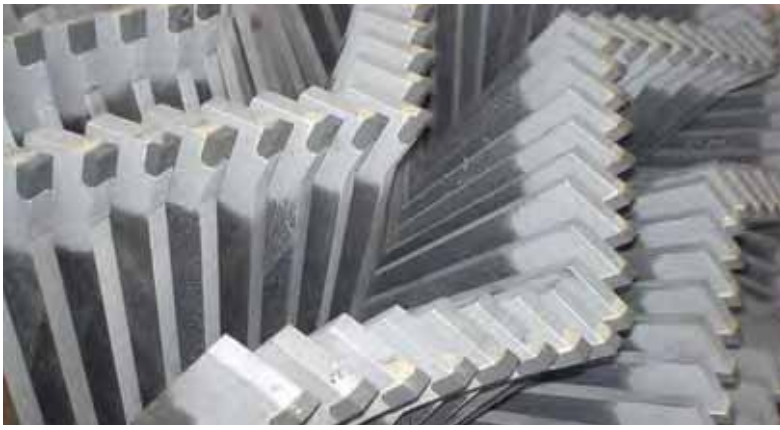

**Sanipro
Partners**

CELLULOSEMILL Special Execution

SPECIAL EXECUTION

CelluloseMILL[®]
SANI - GROUP . COM



Special execution

- Special mills for unique applications,
- Replace existing rotors with new fixed blade style,
- Rebuild rotors including carbide tipping, and balancing,
- Special feeding width or outfeed exits.

Reconditioning steps

- Disassemble,
- Clean & Respect,
- Replace & Repair,
- New Carbide Tips,
- Sharpen Blades,
- Reassemble,
- Balance,
- Final Inspection.

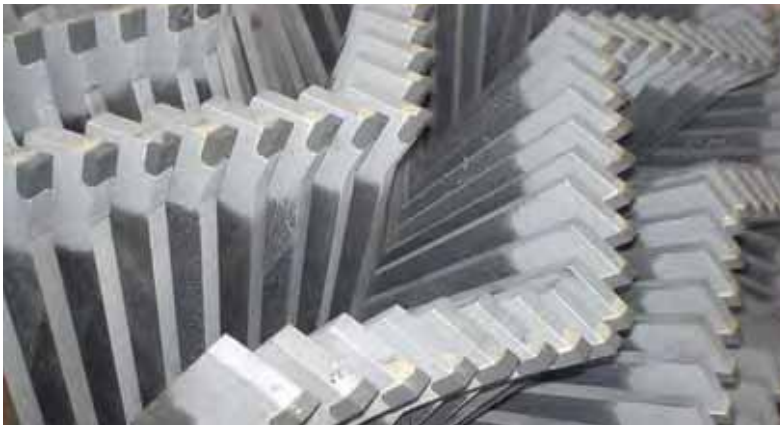

+ Sanipro
+ Partners

CELLULOSEMILL Service

SERVICE

CelluloseMILL[®]
SANI - GROUP . COM

We are specialist in **cellulose defiberization** for many industries. Our **Mills** are delivered world wide.

We offer a benchmark for our customers to test their cellulose or other New Application.

We offer spare parts for mills wearing components such as rotors, bearings, breaking bars, motors, connecting junction with the drum forming.

All our mill rotors are delivered balanced, packed in wooden case and ready to be assembled.

Our rotor can be of standard hard metal or with carbide insertion on all teeth of hammers or discs.

www.cellulosemill.com



SANI-GROUP world references



- Algeria
- Belgium
- Bolivia
- Brazil
- Egypt
- France
- Germany
- Greece
- India
- Iran
- Italy
- Kenya
- Jordan
- Lebanon
- Libya
- Pakistan
- Poland
- Portugal
- Rep. Czech
- Saudi Arabia
- Siria
- Slovenia
- Slovakia
- South Africa
- Tunisia
- Turkey
- United Kingdom
- United Arab Emirates
- USA
- Venezuela



OFFICE

VIALE MONTE SIRENTE 15
66023 - FRANCAVILLA AL MARE (CH) - ITALY



FACTORY

VIA DELLE CONTRADE SN
65012 - VALLEMARE DI CEPAGATTI (PE) - ITALY

TEL + 39 085.45.54.330 / 91.99.604

FAX + 39 085.69.37.97

EMAIL info@cellulosemill.com

HTTP://www.cellulosemill.com



PART OF SANI-GROUP

HTTP://www.sani-group.com